

Customer No.: 32030240
AVC Model: DYPA0838B8UP001

Rev. B

SPECIFICATION FOR APPROVAL

1. SCOPE:

THIS SPECIFICATION DEFINES THE ELECTRICAL AND MECHANICAL CHARACTERISTICS OF THE DC BRUSHLESS FAN.

2. CHARACTERS:

(AT Ta=25°C)

	ITEM	SPEC.
2-1.	RATED VOLTAGE	48 VDC
2-2.	OPERATION VOLTAGE	36.0 ~ 75.0 VDC
2-3.	RATED CURRENT (IN FREE AIR)	0.70 (0.84 MAX.) A (AVERAGE)
2-4.	CURRENT ON LABEL	0.90 A
2-5.	RATED POWER (IN FREE AIR)	33.6 (40.32 MAX.) W
2-6.	START PEAK CURRENT (IN FREE AIR)	1.50 (MAX) A
2-7.	SPEED (IN FREE AIR)	9500±10% R.P.M
2-8.	SPEED CONTROL TYPE	PWM CONTROLLER
2-9.	SIGNAL OUTPUT	FREQUENCY GENERATOR (FG)
2-10.	MAX. AIR FLOW (AT ZERO STATIC PRESSURE)	3.520 (3.168 MIN.) M ³ /MIN 124.29 (111.86 MIN.) CFM
2-11.	MAX. AIR PRESSURE (AT ZERO FLOW)	45.64 (36.97 MIN.) mm-H ₂ O 1.797 (1.456 MIN.) inch-H ₂ O
2-12.	ACOUSTICAL NOISE	61.0 (64.0 MAX.) dB-A



Customer No.:	32030240
AVC Model:	DYPA0838B8UP001

- 2-13. INSULATION RESISTANCE — 10 MEGA OHM MIN. AT 500 VDC
(BETWEEN FRAME AND (+) TERMINAL)
- 2-14. DIELECTRIC STRENGTH — 5 mA MAX. AT 500 VAC 60Hz ONE MINUTE,
(BETWEEN FRAME AND (+) TERMINAL)
- 2-15. INSULATION CLASS — UL: CLASS A

NOTE:

- A. THE VALUES WRITTEN IN PARENTHESIS, (), ARE LIMITED SPEC.
- B. ACOUSTICAL NOISE MEASURING CONDITION:

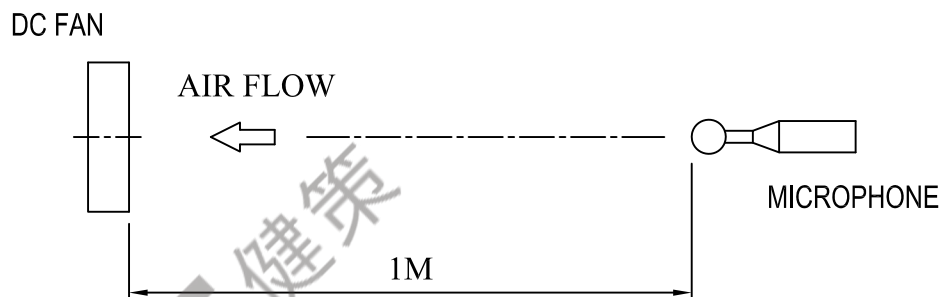

NOISE IS MEASURED AT RATED VOLTAGE IN FREE AIR IN ACOUSTICAL CHAMBER WITH LARSON DAVIS TYPE 824S SOUND LEVEL METER.

- C. THE AIR FLOW AND AIR PRESSURE MEASURED AT RATED VOLTAGE IN DOUBLE CHAMBER IS MEASURED ACCORDING TO AMCA STANDARD 210-85.

Customer No.:	32030240
AVC Model:	DYPA0838B8UP001

3. MECHANICAL

- 3-1. DIMENSION _____ SEE DIMENSION DRAWING
- 3-2. FRAME _____ THERMOPLASTIC OF UL 94V-0
- 3-3. FAN BLADE _____ THERMOPLASTIC OF UL 94V-0
- 3-4. BEARING SYSTEM _____ TWO BALL BEARINGS
- 3-5. WEIGHT _____ 198 g

4. ENVIRONMENTAL

- 4-1. OPERATING TEMPERATURE _____ -25 TO +75 °C
- 4-2. STORAGE TEMPERATURE _____ -40 TO +75 °C
- 4-3. OPERATING HUMIDITY _____ 5 TO 90 % RH
- 4-4. STORAGE HUMIDITY _____ 5 TO 95 % RH
- 4-5. DROP TEST _____
IN MINIMUM PACKAGING CONDITION FAN WITHSTAND EACH ONE
DROP OF THREE FACES FROM 30cm DISTANCE HEIGHT ONTO 10mm
THICKNESS OF WOODEN BOARD
- 4-6. VIBRATION TEST _____
SINEWAVE
DISPLACEMENT AMPLITUDE: 0.75 mm (EQUIVALENT 10G)
FREQUENCY RANGE: 10Hz - 55 Hz / 30 SEC. 55Hz - 10 Hz / 30 SEC.
LINEAR SCANNING 120 CYCLE
ENDURANCE TIMER PER AXIS: 2 HOURS
ORIENTATION: X,Y,Z
- 4-7. SHOCK TEST _____
APPLY PEAK ACCELERATION 50 G AND KEEP DURATION OF THE
PLUSES FOR 11mS (HALF SINE WAVE)
- 4-8. RoHS COMPLIANCE _____ SEE RoHS STANDARD

5. PROTECTION

- 5-1. LOCKED ROTOR PROTECTION _____
IMPEDANCE OF MOTOR WINDING PROTECTS MOTOR FROM DAMAGE IN
72 HOURS OF LOCKED ROTOR CONDITION AT THE RATED VOLTAGE
- 5-2. POLARITY PROTECTION _____
BE CAPABLE OF WITHSTANDING IF REVERSE CONNECTION FOR
POSITIVE AND NEGATIVE LEADS
- 5-3. HOT SWAP PROTECTION _____ THIS FAN HAS NO HOT SWAP FUNCTION .

Customer No.:	32030240
AVC Model:	DYPA0838B8UP001

6. P & Q CURVE

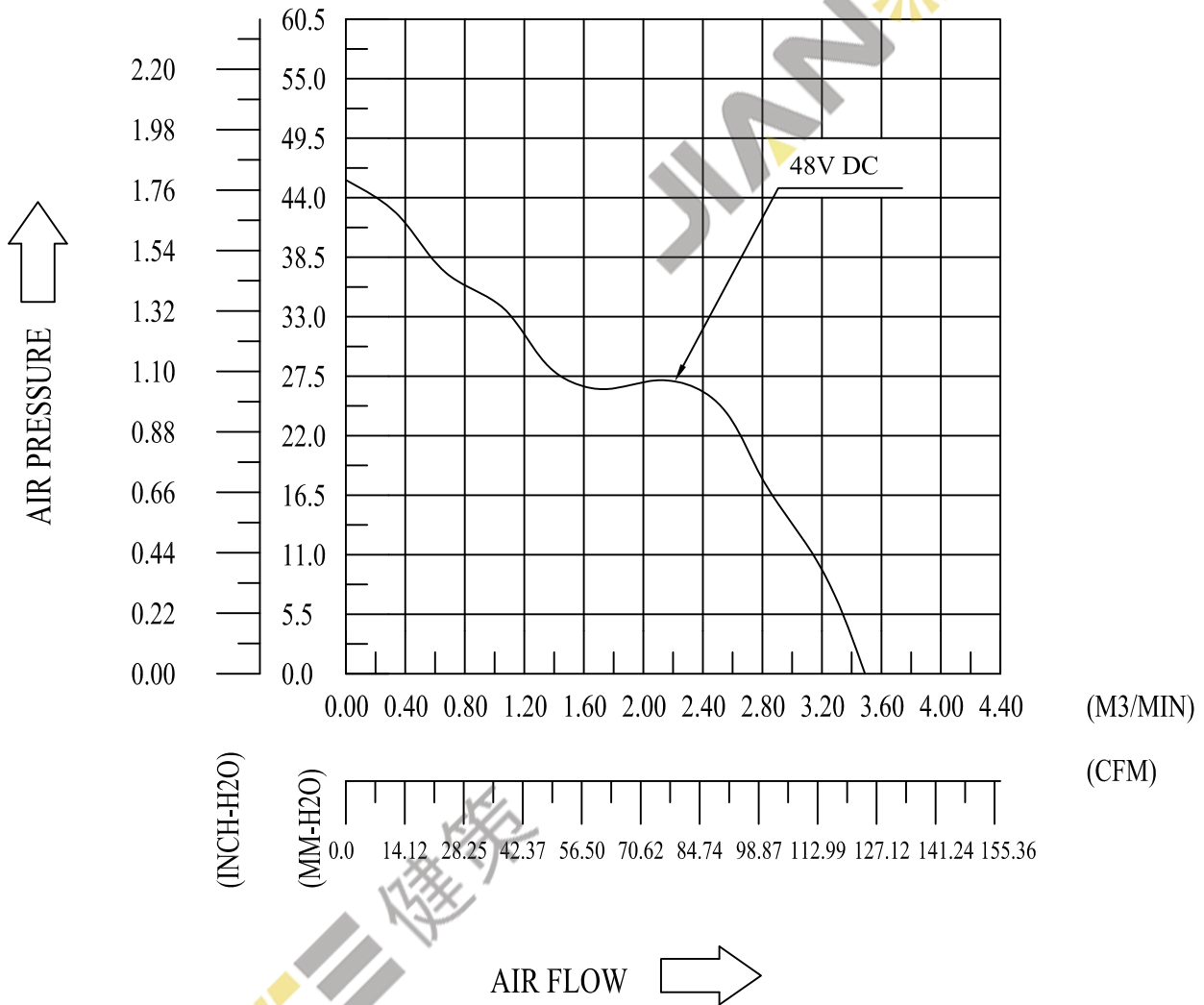

* TEST CONDITION:

INPUT VOLTAGE	——	OPERATION VOLTAGE
TEMPERATURE	——	ROOM TEMPERATURE
HUMIDITY	——	65%RH

Customer No.: 32030240
AVC Model: DYPA0838B8UP001

7. DIMENSION DRAWING

條碼列印處
21AAAAAAA
4JYMXXXXX Y
①客戶料號:AAAAAAA
②年月:YM
③流水號:XXXXXX

- 產品料號對應之打印內容請參照下表:
 - 年份"Y": 2010年開始, 採用26個字母表示年份位, 其中"A"表示2010年, "A"-"Z"遞增表示後續各年份。
 - 月份"M": 1,2,3,4,5,6,7,8,9,A,B,C (月份為兩位數時,以字母代替,如A(10), B(11), C(12))
 - 流水號: 000001~999999
- 二維條碼信息內只需要20位, 第二行文字最后一碼'Y'只在文字部份顯示, 不能顯示在二維條碼掃描區域的信息內。

BACKGROUND COLOR: GOLD
WORD COLOR: WHITE
BACKGROUND COLOR: WHITE
WORD COLOR: BLACK

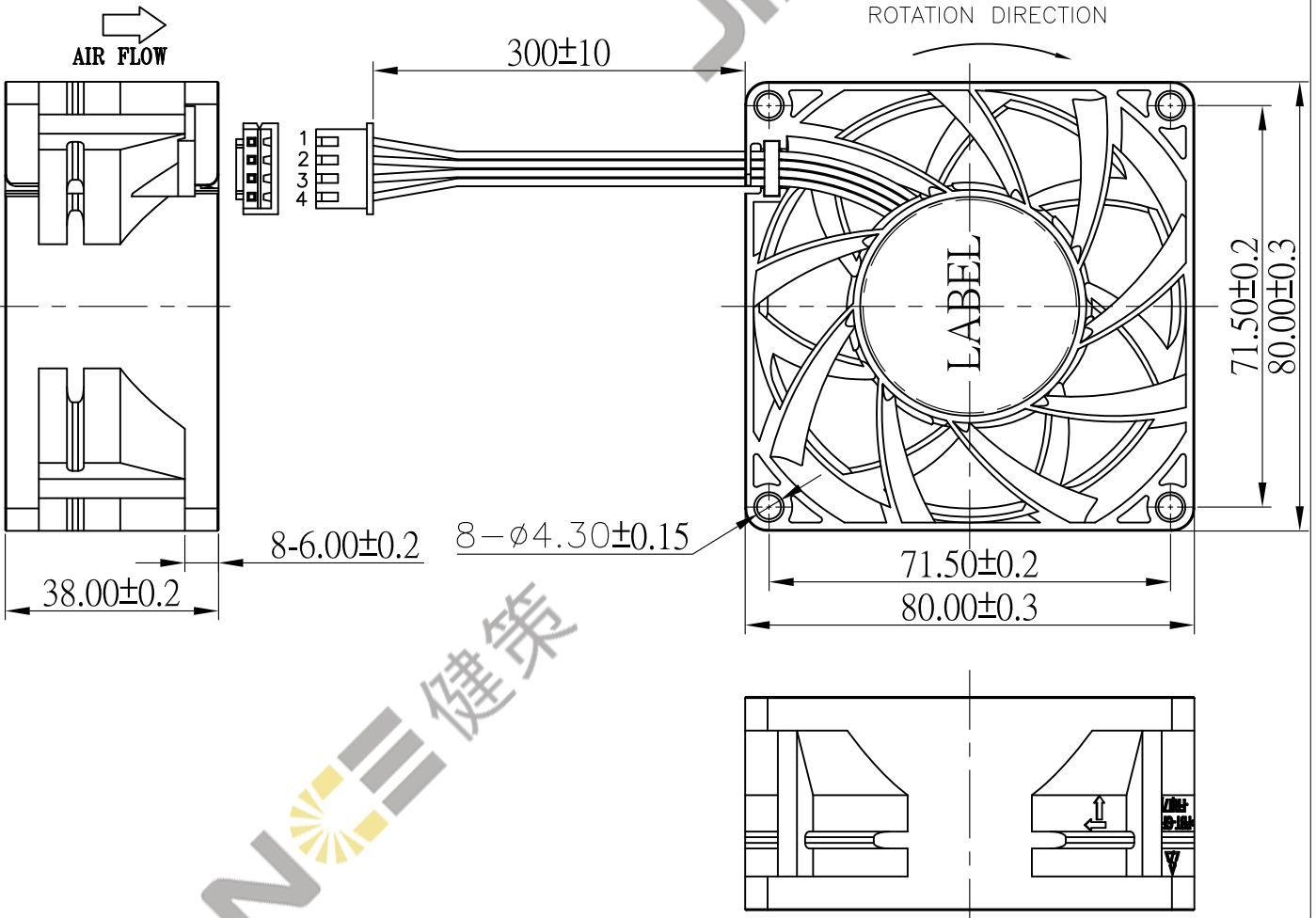
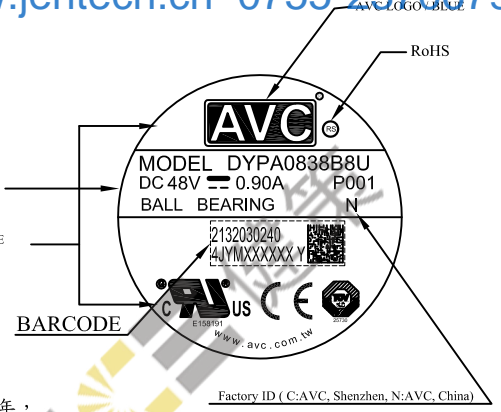

NOTES: 1. LEAD WIRES: PVC WIRES UL1430 AWG#28
PIN 1 : RED WIRE (+)
PIN 2 : YELLOW WIRE (PWM)
PIN 3 : BLUE WIRE (FG)
PIN 4 : BLACK WIRE (-)

2. CONNECTOR:
HOUSING : JWT A2501H02-4P OR EQUIVALENT
TERMINAL : JWT A2501TOP-2 OR EQUIVALENT

3. BARCODE LABEL SHOWS TRACEABLE INFO. IT IS AVAILABLE ON ENGINEERING MANUFACTURE.

UNIT: mm

Customer No.:	32030240
AVC Model:	DYPA0838B8UP001

7-2. MOUNTION PANEL CUTOUT

INLET SIDE

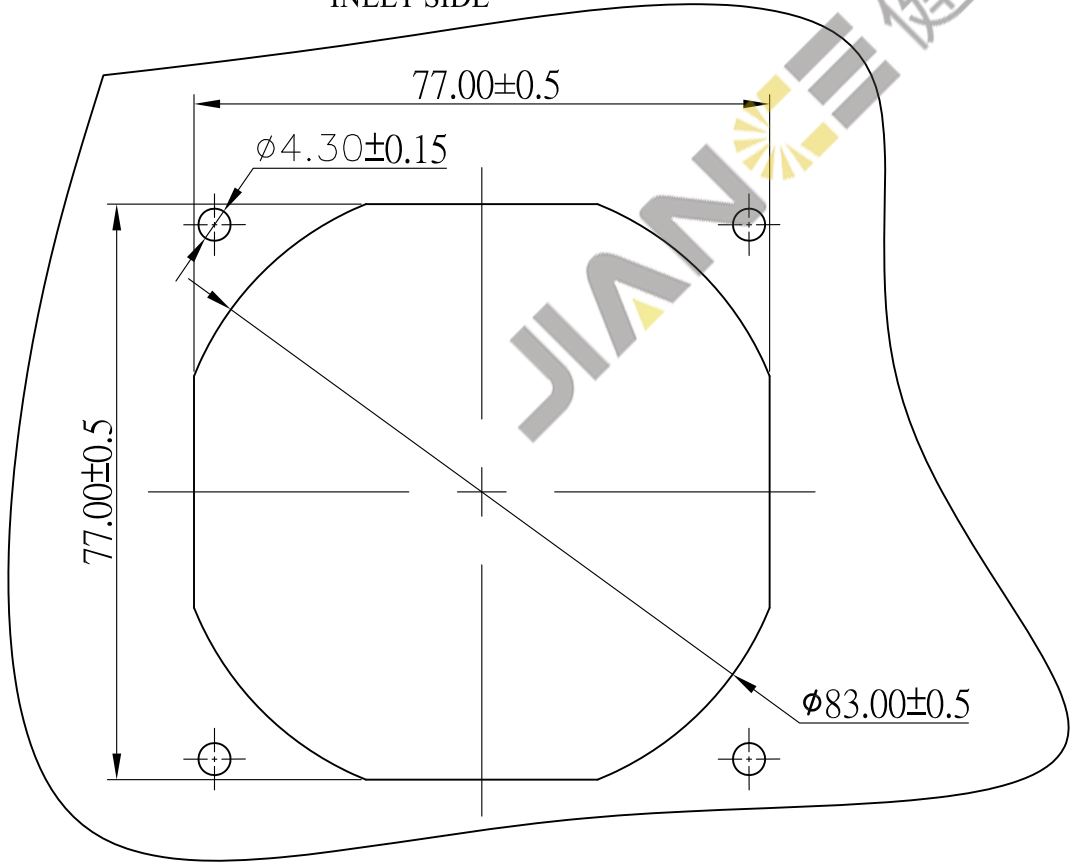

OUTLET SIDE

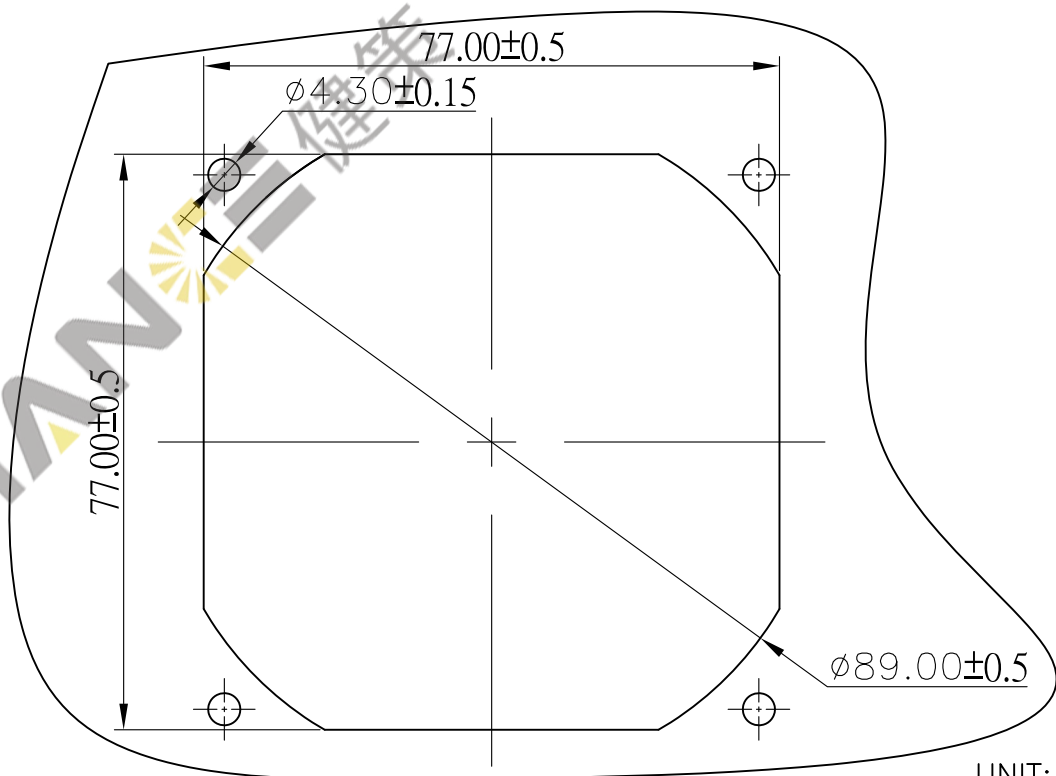

UNIT: mm

Customer No.:	32030240
AVC Model:	DYPA0838B8UP001

8. SPEED CONTROL FUNCTION

8-1. PWM SIGNAL DESCRIPTION :

- CONTROL SIGNAL: PWM CONTROL
- THE RANGE OF SIGNAL VOLTAGE: LOW LEVEL VOLTAGE: MAX.<0.4V, MIN. >-0.8V
HIGH LEVEL VOLTAGE:MAX.<20V, MIN. >2.8V
- THE FREQUENCY OF PWM SINGAL SHALL BE ABLE TO ACCEPT A 300Hz~60KHz.
- INPUT IMPEDANCE : 20K OHM MIN.

8-2. FAN SPEED CONTROL DESCRIPTION

- FAN INPUT VOLTAGE (POSITIVE) : 48VDC
- PWM FREQUENCY : 1KHZ
- THE FAN SPEED WILL SPIN AT MAXIMUM WHEN THE DUTY CYCLE IS 100%.
- THE FAN SPEED WILL STOP WHEN THE DUTY CYCLE IS 0%.
- THE FAN SPEED WILL SPIN AT 1400~9500 RPM WHEN THE DUTY CYCLE IS 10%~100%.
- THE FAN SPEED WILL SPIN AT MAXIMUM WHEN THE LEAD WIRE OF PWM SIGNAL DISCONNECTED.
- THE FAN WILL BE ABLE TO START WHEN THE DUTY CYCLE IS 10% .
- THE FAN SPEED WILL SPIN USE CLOSE LOOP CONTROL .

8-3. PWM DUTY CYCLE VS. RPM (AT Ta=25°C)

DUTY CYCLE(%)	NOMINAL RPM	RPM TOLERANCE	CURRENT(A) TYPICAL	MAX CURRENT(A)
0%	0	0	0.02	0.03
10%	1400	±300	0.03	0.05
50%	4450	±10%	0.10	0.15
100%	9500	±10%	0.70	0.84

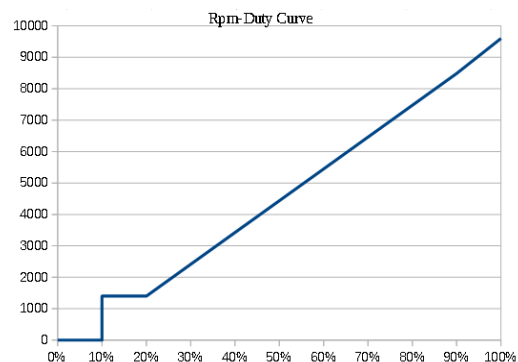
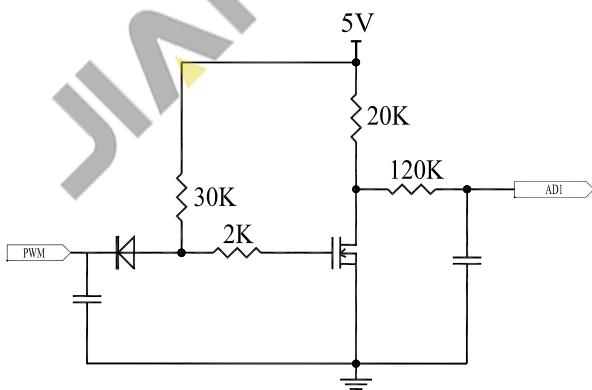

Customer No.:	32030240
AVC Model:	DYPA0838B8UP001

9. P-Q (For reference only)

9-1. PWM DUTY CYCLE VS. P-Q (AT Ta=25°C)

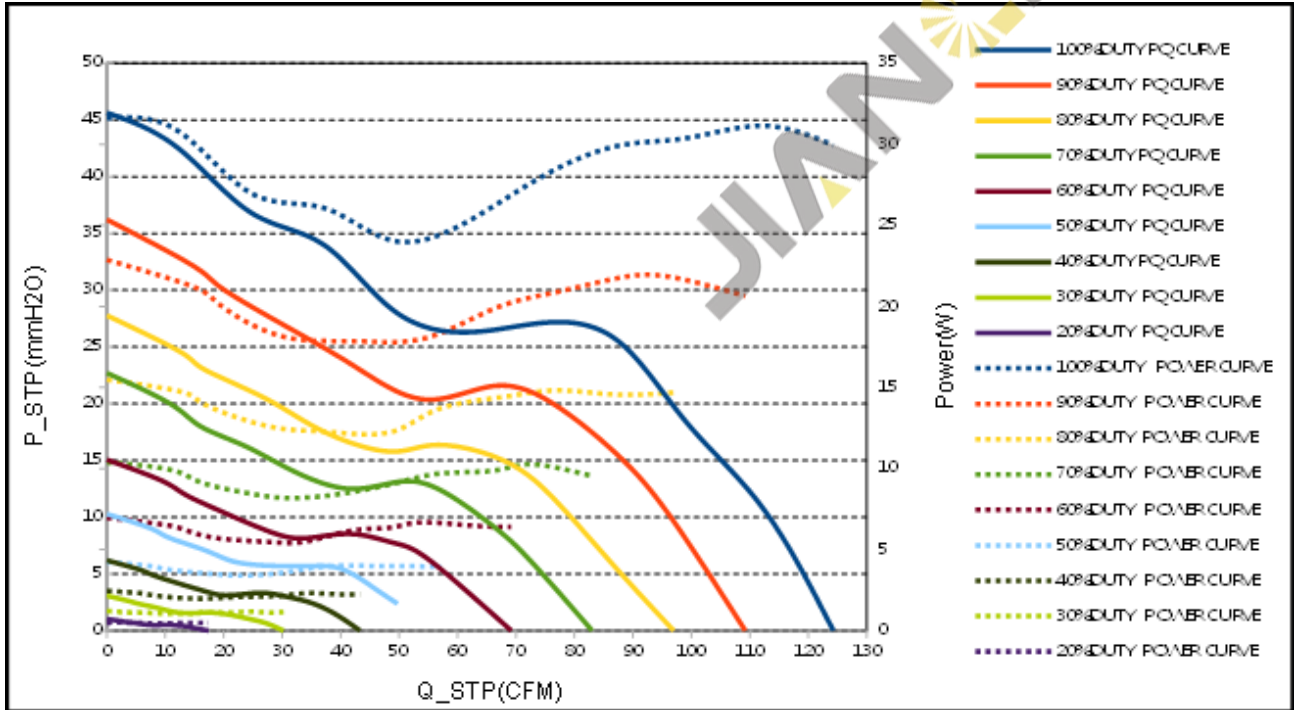

9-2. OPERATION VOLTAGE VS. P-Q

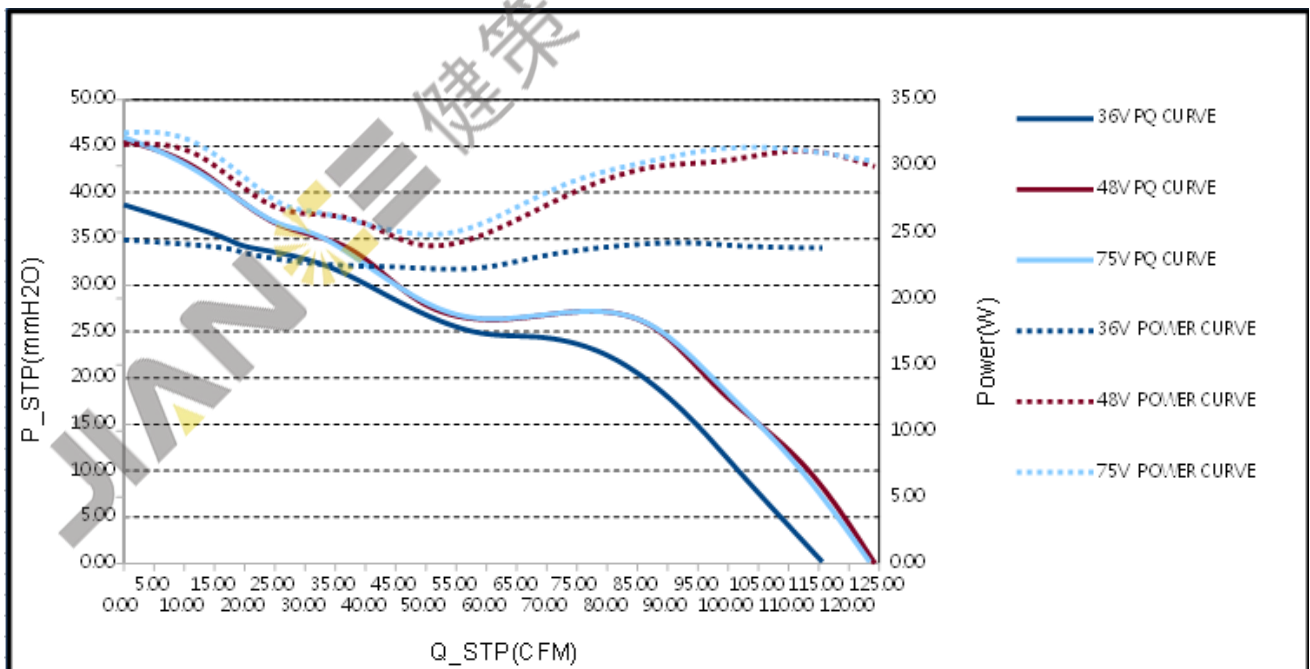

Customer No.:	32030240
AVC Model:	DYPA0838B8UP001

10.FREQUENCY GENERATOR (FG) SIGNAL

10-1. SCHEMATIC:

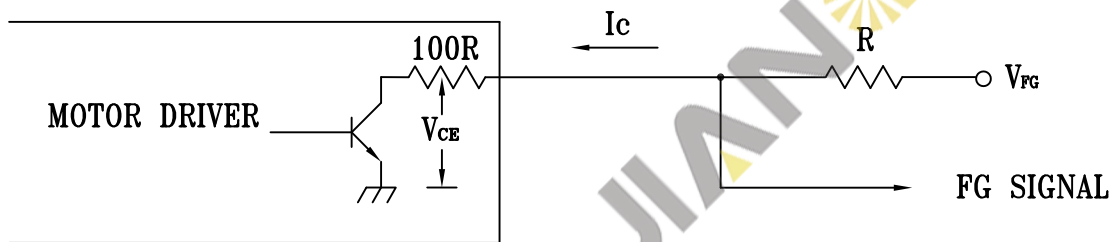

CAUTION:

THE LEAD WIRE OF FG SIGNAL CAN NOT TOUCH THE LEAD WIRE OF POSITIVE OR NEGATIVE.

10-2. SIGNAL SPECIFICATION:

OUTPUT TYPE: OPEN COLLECTOR

V_{FG} MAXIMUM VOLTAGE = 75V

V_{FG} MINIMUM VOLTAGE = 2.8V

I_c MAXIMUM CURRENT = 5mA

LOW LEVEL VOLTAGE = 1.5V MAX.

$R \geq V_{FG} / I_c$

10-3. FREQUENCY GENERATOR WAVEFORM:

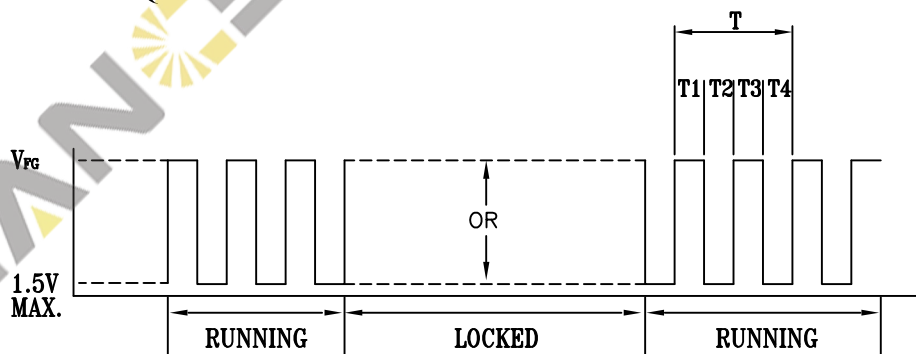

$$T = T_1 + T_2 + T_3 + T_4 = 60/N \text{ (Sec)}$$

N: SPEED (RPM)

FAN INSTALLATION INSTRUCTIONS:

- In case of using bolt-nut fasteners, the flatness of chassis mating surfaces should be kept below 0.1mm.
- How to fasten the frames of different types:
 - Flange type : Screw the bolt and nut together from the inlet or outlet.
The torque should not exceed 4.5 kgf-cm [figure(a)]
 - Rib type : Screw the bolt through the rib.
The torque should not exceed 7.5 kgf-cm [figure(b)]
- In case of using self-tapping screws, appropriate screws according to JIS B 1122 Type 2 should be used. The dimensional details of the self-tapping screws recommended are shown in Table(a). Each fastener hole should only be tightened once or slippage may occur. In addition, the torque to be applied to the self-tapping screws must not exceed the values stated in Table(a).
- The countersunk part of fastener head should not interfere with the frame or there would be a risk of breakage [figure(e)]. Fastener head with flat inner surface, i.e. no countersunk, is recommended.

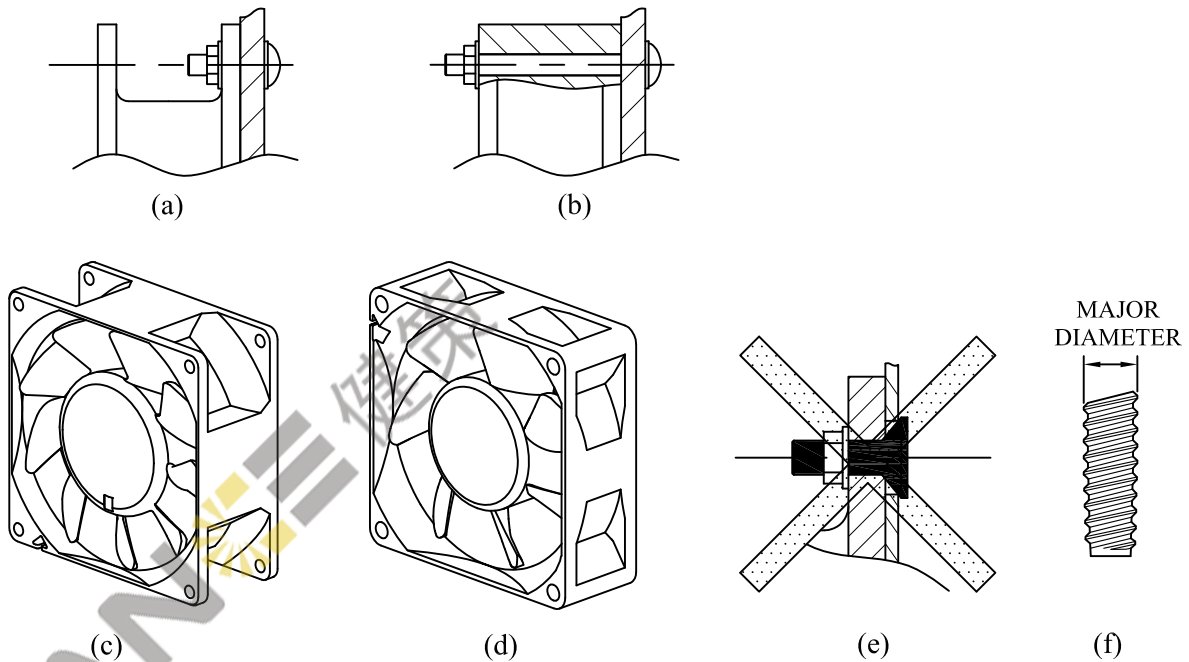

MOUNTING HOLE DIAMETER	SCREW SPEC.	MAJOR DIAMETER [Fig.(f)]		**RECOMMENDED MAX. TORQUE (kgf-cm)	
		MAXIMUM	MINIMUM	FLANGE TYPE FRAME	RIB TYPE FRAME
ø3.5	M4 X 1.41	4.0	3.85	4.5	7.5
*ø4.3	M4.8 X 1.59	4.8	4.65	5.5	7.5
ø4.5	M5 X 1.59	5.0	4.85	5.5	7.5

* Non JIS B 1122 spec.

** A lower torque than the recommended value should be used if slippage is observed.

TABLE (a)



Description:

1. If the products are applied outside the parameters set in the specification, AVC is not responsible for the performance of the products.
2. Should customers request deviation from specification, they must first submit written request to AVC for approval.
3. Please use proper care when handling fans. Improper handling of the impeller, lead wires, or drop to the floor may lead to damage.
4. AVC will not guarantee that the products will be safe to use if there are problems caused by powder, water, and corrosive fluids.
5. Please double check on the correct polarity before connecting the fan to the power source.
6. Fans must not be stored in a high humidity environment. They should be stored according to the specified storage temperature limits. Fans must be tested again for performance before shipment if the fans are stored for more than 6 months.
7. Incorrect setting up of fans will very likely lead to excess vibration and acoustic noise.
8. During fan testing, we must take precautions against personal injury . Suitable fan guards must be fitted to the fans if needed.
9. Unless stated in specification, all fan performance tests are to be carried out at relative temperature and humidity conditions at 25°C , 65%.
10. When using multiple fans in parallel, please make sure to connect capacitor at least 4.7uF to avoid any unstable power.

RoHS STANDARD

HAZARDOUS SUBSTANCES		ALLOWABLE CONTENT (wt%)	REMARK
HEAVY METALS	CADMIUM (Cd) AND ITS COMPOUNDS	< 0.01 wt% (< 100 ppm)	DIRECTIVE 2011/65/EU
	LEAD (Pb) AND ITS COMPOUNDS	< 0.1 wt% (< 1000 ppm)	DIRECTIVE 2011/65/EU
	MERCURY (Hg) AND ITS COMPOUNDS	< 0.1 wt% (< 1000 ppm)	DIRECTIVE 2011/65/EU
	HEXAVALENT CHROMIUM (CHROMIUM VI) (Cr ⁶⁺) AND ITS COMPOUNDS	< 0.1 wt% (< 1000 ppm)	DIRECTIVE 2011/65/EU
BROMINATED FLAME RETARDANTS	POLYBROMINATED BIPHENYLS (PBBs)	< 0.1 wt% (< 1000 ppm)	DIRECTIVE 2011/65/EU
	POLYBROMINATED DIPHENYL ETHERS (PBDEs)	< 0.1 wt% (< 1000 ppm)	DIRECTIVE 2011/65/EU