

# DC AXIAL FANS

## DATB SERIES 60x60x25 mm

- \* Material: Impeller & Frame: Plastic (UL 94V-0)
- \* Lead Wires: UL 1007 AWG #28 or Equivalent
- \* Impeller: 7 Blades
- \* Rotational direction CCW view from front face
- \* Weight: 80.0g (2.82 OZ)



ASIA VITAL COMPONENTS CO., LTD. SixSigma

MODEL	Bearing Type	Rated Voltage	Operating Voltage Range	Rated Current	Rated Input Power	Speed	Maximum Air Flow	Maximum Air Pressure	Acoustic Noise	Life expectancy L10@40°C			
PART NO.	SIGNAL	B.T.S.R	VDC	VDC	Amp	Watt	R.P.M.	m <sup>3</sup> /min	CFM	mmH <sub>2</sub> O	IN H <sub>2</sub> O	dB-A	hours
DATB0625_2E	-FG / RD	B	12	7 to 13.2	0.11	1.32	4200	0.659	23.29	5.23	0.206	34.2	150000
DATB0625_2L	-FG / RD	B	12	7 to 13.2	0.15	1.80	5000	0.785	27.73	7.42	0.292	38.3	140000
DATB0625_2M	-FG / RD	B	12	7 to 13.2	0.22	0.64	6000	0.954	33.68	10.46	0.412	42.6	140000
DATB0625_2H	-FG / RD	B	12	7 to 13.2	0.33	3.96	6800	1.104	38.98	13.20	0.520	46.2	105000
DATB0625_2U	-FG / RD	B	12	7 to 13.2	0.45	5.40	7400	1.203	42.49	16.00	0.63	48.9	105000
DATB0625_2S	-FG / RD	B	12	7 to 13.2	0.54	6.48	8200	1.324	46.76	19.40	0.764	50.6	70000
* DATB0625_2F	-FG / RD	B	12	7 to 13.2	0.72	8.64	9000	1.475	52.08	23.90	0.941	54.0	70000

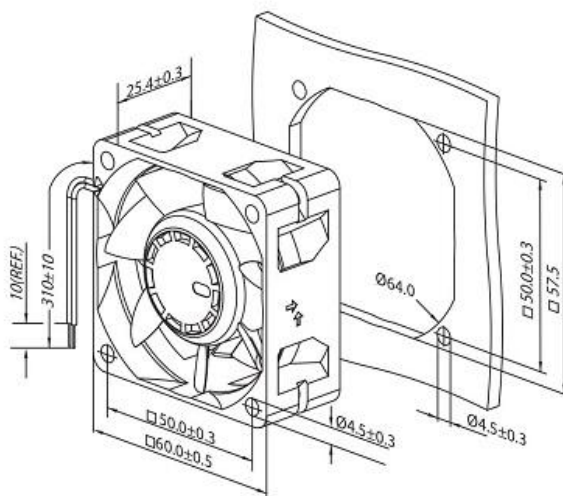
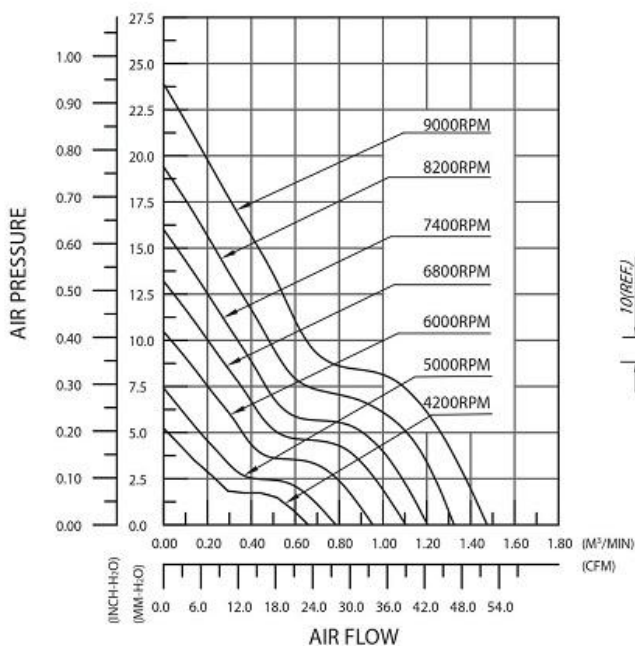

# DC AXIAL FANS



## DATB SERIES

60x60x25 mm 48v

- \* Material: Impeller & Frame: Plastic (UL 94V-0)
- \* Lead Wires: UL 1007 AWG #28 or Equivalent
- \* Impeller: 7 Blades
- \* Rotational direction CCW view from front face
- \* Weight: 80.0g (2.82 OZ)

ASIA VITAL COMPONENTS CO., LTD. SixSigma

MODEL	Bearing Type	Rated Voltage	Operating Voltage Range	Rated Current	Rated Input Power	Speed	Maximum Air Flow	Maximum Air Pressure	Acoustic Noise	Life expectancy L10@40°C			
PART NO.	SIGNAL	B.T.S.R	VDC	VDC	Amp	Watt	R.P.M.	m <sup>3</sup> /min	CFM	mmH <sub>2</sub> O	IN H <sub>2</sub> O	dB-A	hours
DATB0625_8E	-FG / RD	B	48	28 to 56	0.06	1.92	4200	0.659	23.29	5.23	0.206	34.2	150000
DATB0625_8L	-FG / RD	B	48	28 to 56	0.07	2.40	5000	0.785	27.73	7.42	0.292	38.3	140000
DATB0625_8M	-FG / RD	B	48	28 to 56	0.09	3.36	6000	0.954	33.68	10.46	0.412	42.6	140000
DATB0625_8H	-FG / RD	B	48	28 to 56	0.12	4.80	6800	1.104	38.98	13.20	0.520	46.2	105000
DATB0625_8U	-FG / RD	B	48	28 to 56	0.13	5.28	7400	1.203	42.49	16.00	0.63	48.9	105000
DATB0625_8S	-FG / RD	B	48	28 to 56	0.17	7.20	8200	1.324	46.76	19.40	0.764	50.6	70000
* DATB0625_8F	-FG / RD	B	48	28 to 56	0.21	9.12	9000	1.475	52.08	23.90	0.941	54.0	70000

